

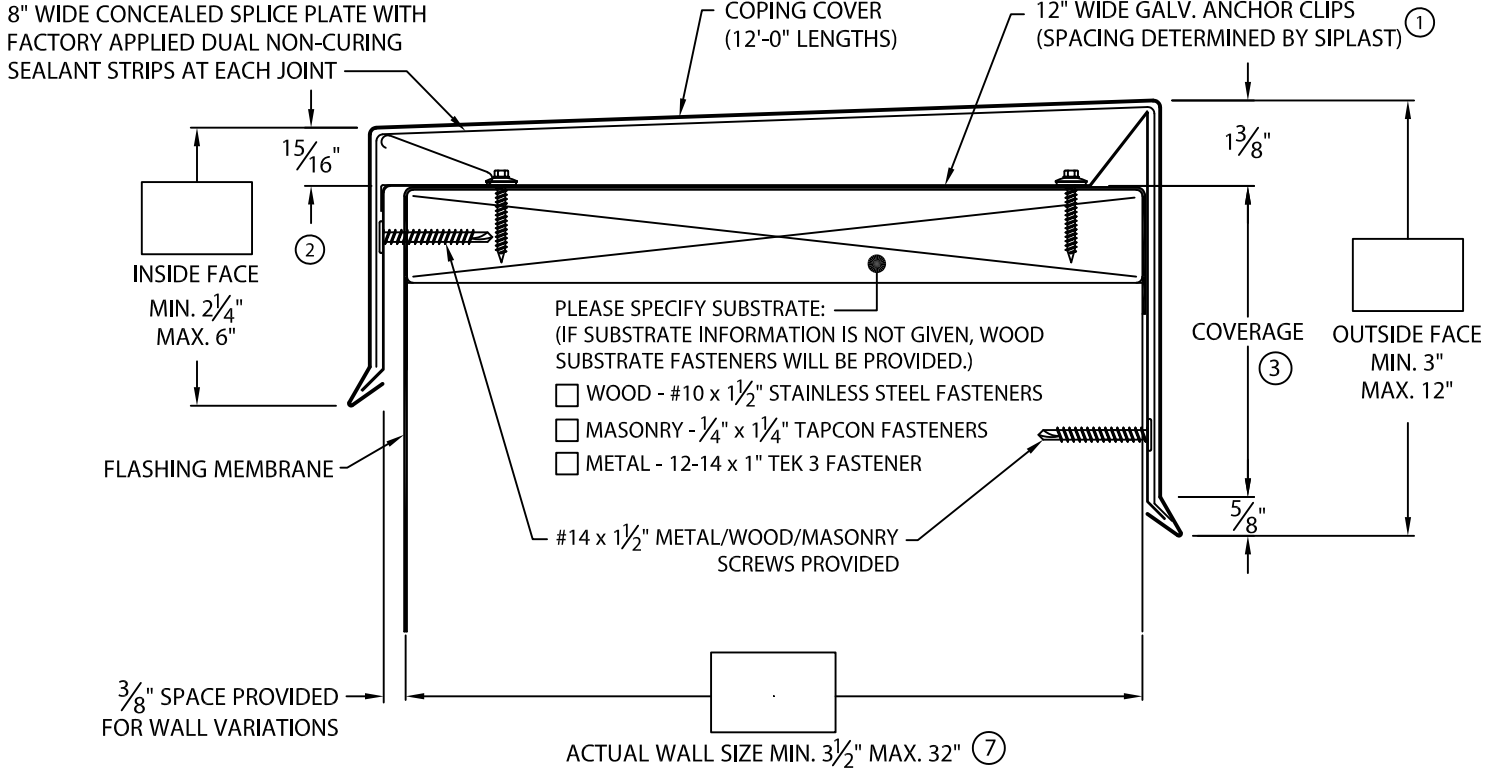

# PARAGUARD M COPING

## TAPERED VERSION



### NOTES:

- ① ANCHOR CLIP PROFILE ON WALLS GREATER THAN 14".
- ② IF WALL SIZE IS OVER 16", THE RISE IS 5/8".
- ③ FACE = COVERAGE (SHOULD EXTEND A MIN. OF 1" BELOW FLASHING MEMBRANE) + 2".
- ④ 24 GA. GALV. AND .040" ALUM. COPING COVERS AVAILABLE FOR WALL SIZES 3 1/2" TO 24" ONLY.
- ⑤ WELDED ACCESSORIES REQUIRE A MINIMUM MATERIAL THICKNESS OF .050".
- ⑥ FOR NON 90° MITERS PLEASE USE PRINT APPROVAL #44011-28217.
- ⑦ WALL SIZE INCLUDES MEMBRANE FLASHING THICKNESS.

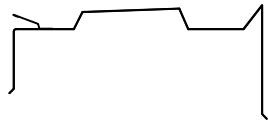

### MATERIAL:

\_\_\_ 24 GA. GALVANIZED STEEL ④ \_\_\_ .040" ALUMINUM ④  
 \_\_\_ 22 GA. GALVANIZED STEEL \_\_\_ .050" ALUMINUM  
 \_\_\_ OTHER \_\_\_\_\_ \_\_\_ .063" ALUMINUM  
 COLOR: \_\_\_\_\_ FINISH: \_\_\_\_\_

### QUANTITIES:

\_\_\_ LINEAL FEET 12'-0" LENGTHS

### ACCESSORIES:

\_\_\_ OUTSIDE MITERS @ 90° ⑥ SPECIFY ACCESSORY TYPE:  
 \_\_\_ INSIDE MITERS @ 90° ⑥  WELDED ⑤  
 \_\_\_ RIGHT ENDCAPS  QUICKLOCK  
 \_\_\_ LEFT ENDCAPS  
 \_\_\_ RIGHT ENDWALL (COPING VERSION)  
 \_\_\_ LEFT ENDWALL (COPING VERSION)  
 \_\_\_ RIGHT ENDWALL (SPLICE PLATE VERSION)  
 \_\_\_ LEFT ENDWALL (SPLICE PLATE VERSION)

AUTHORIZED SIGNATURE:

APPROVED BY: \_\_\_\_\_

DATE: \_\_\_\_\_



ANSI/SPRI ES-1 TESTED

PROJECT:

ROOFING CONTRACTOR:

SHIP TO ADDRESS:

CITY, STATE, ZIP:

PHONE: 800-922-8800  
 EMAIL: PGUARD@SIPLAST.COM

DATE: 12/07/18

DRN BY: JJC

CKD BY: SAK

SHT.# \_\_\_ OF \_\_\_

DWG# 44011-24018

B



# PARAGUARD M COPING

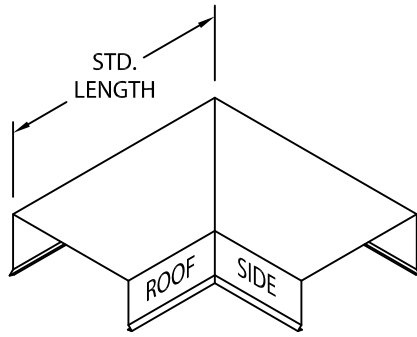

OUTSIDE MITER

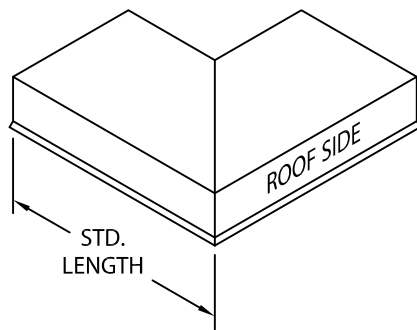

INSIDE MITER

MITER STANDARD LEG LENGTH:  
WALL SIZE + 9<sup>5</sup>/<sub>8</sub>" = LENGTH

## PARAGUARD M COPING STANDARD ACCESSORIES

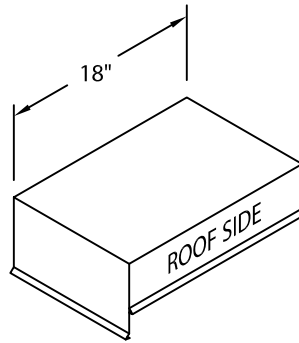

ENDCAP  
(LEFT HAND SHOWN)

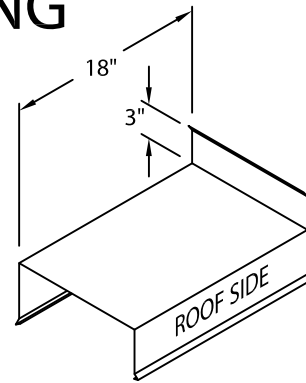

ENDWALL FLASHING  
COPING VERSION  
(RIGHT HAND SHOWN)

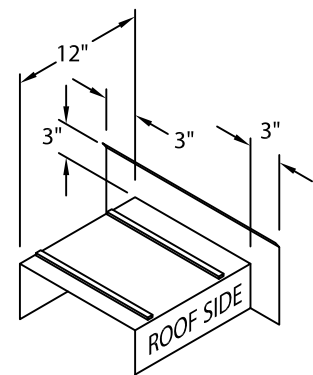

ENDWALL FLASHING  
SPLICE PLATE VERSION  
(RIGHT HAND SHOWN)  
(AVAILABLE ONLY IN  
.040" WELDED, PAINTED  
TO MATCH COPING)

## ADDITIONAL ACCESSORIES ARE AVAILABLE ON WEBSITE:

- TRANSITION MITERS
- STRAIGHT TRANSITION MITERS
- "T" MITERS
- "Z" MITERS
- STEP-UP MITERS
- PEAK / VALLEY MITERS
- PILASTER CAPS
- RADIUS COPING
- ARCHED COPING

(FOR ADDITIONAL ACCESSORY REQUIREMENTS, ATTACH SKETCHES OR CALL MANUFACTURER FOR ASSISTANCE).

## ANCHOR CLIP SPACING:

- 24 GA. / .040", 16" WALL SIZE OR LESS, ANCHOR CLIPS ARE 48" O.C.
- 24 GA. / .040", OVER 16" WALL SIZE, ANCHOR CLIPS ARE 36" O.C.
- 22 GA. / .050" / .063", 26<sup>1</sup>/<sub>2</sub>" WALL SIZE OR LESS, ANCHOR CLIPS ARE 48" O.C.
- 22 GA. / .050" / .063", OVER 26<sup>1</sup>/<sub>2</sub>" WALL SIZE, ANCHOR CLIPS ARE 36" O.C.
- FLORIDA JOBS HAVE ANCHOR CLIPS 36" O.C. FOR ALL WALL SIZES.

ANCHOR CLIP MATERIAL IS 20 GA. GALV. FOR ALL WALL SIZES UP TO 26<sup>1</sup>/<sub>2</sub>".  
16 GA. GALV. FOR ALL WALL SIZES GREATER THAN 26<sup>1</sup>/<sub>2</sub>"

PHONE: 800-922-8800  
EMAIL: PGUARD@SIPLAST.COM

DATE: 12/07/18  
DRN BY: JJC  
CKD BY: SAK

SHT.# \_\_\_ OF \_\_\_

DWG# 44011-24018

B