

INDEPENDENT WALL FLASHING

PARAFLEX LIQUID MEMBRANE - CONCRETE SUBSTRATE

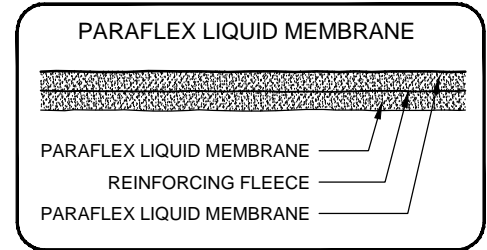

L-METAL INSTALLATION JOINT TREATMENT

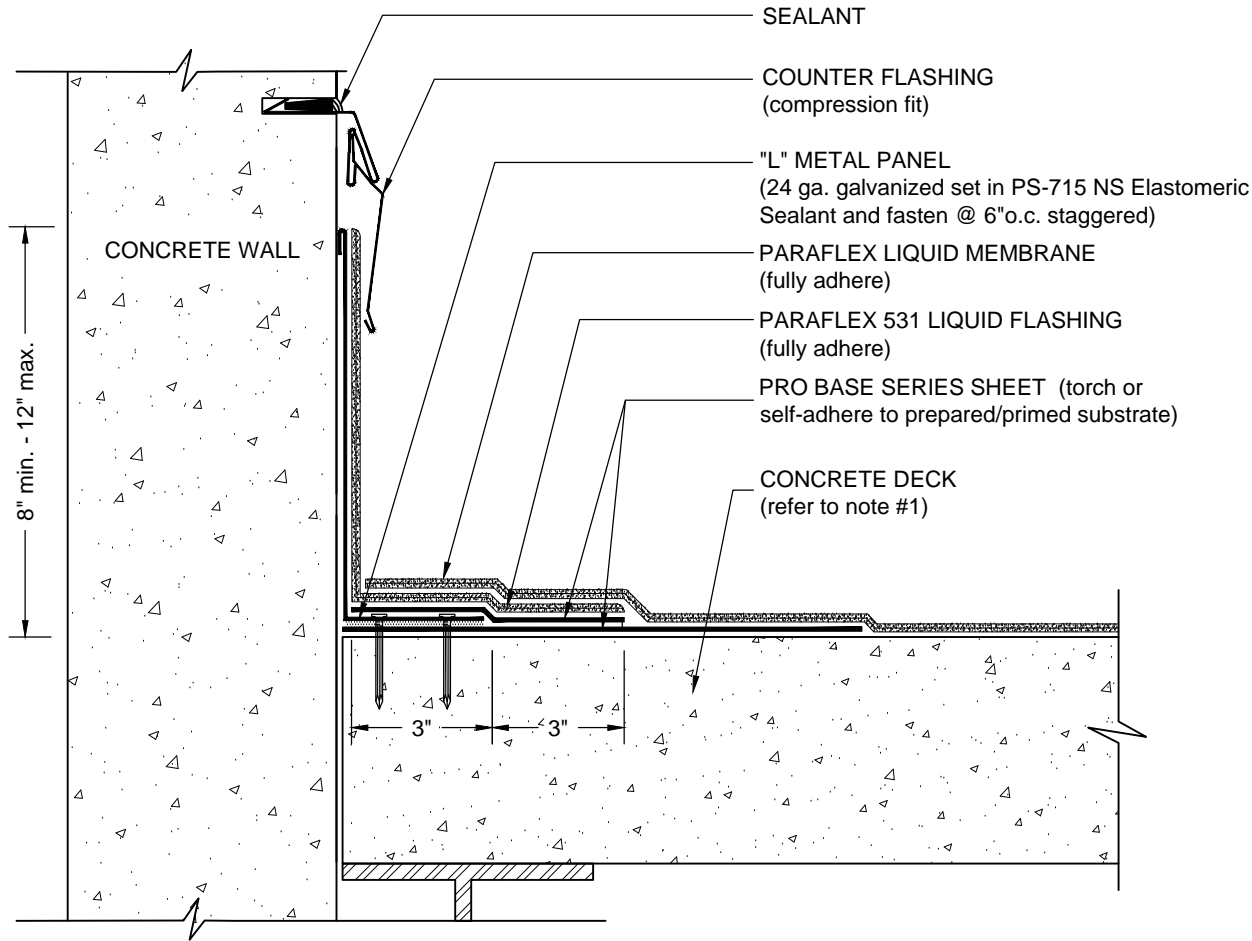
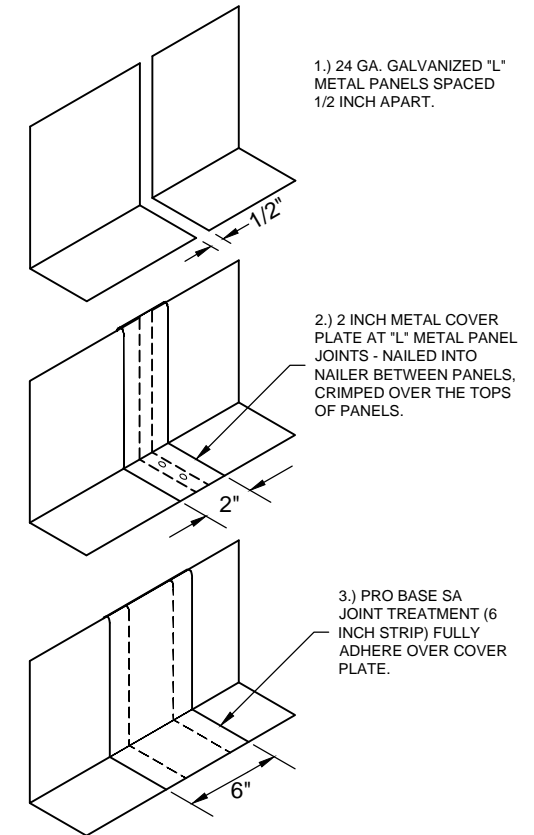

NOTES:

1. REFER TO SIPLAST PREPARATION GUIDELINES FOR PROPER SURFACE TREATMENT OF ALL MATERIALS PRIOR TO APPLICATION OF PRO BASE SERIES SHEETS OR PARAFLEX MATERIALS.
2. TREAT JOINTS BETWEEN SECTIONS OF "L" METAL WITH A 2" COVER PLATE AND A 6 INCH WIDE STRIP OF PRO BASE SA.
3. CONTACT SIPLAST FOR FURTHER INFORMATION ON SELECTING THE APPROPRIATE PRO BASE SERIES SHEET FOR A SPECIFIC PROJECT.
4. PRIME THE BLEEDOUT AT SIDE AND END LAPS OF PRO BASE PLY SHEETS USING PRO PRIMER AC TO MAINTAIN A CONSISTENT AESTHETIC APPEARANCE OF THE FINISHED PARAFLEX SYSTEM.
5. REQUIREMENTS AND RECOMMENDATIONS DETAILED IN CURRENT SIPLAST SPECIFICATIONS AND THE PARAFLEX LIQUID MEMBRANE SYSTEM INSTALLER'S GUIDE SHALL APPLY IN ADDITION TO THE ABOVE DRAWING.

CAUTION: SIPLAST RECOMMENDS THAT ALL PRACTICES PERTAINING TO NRCA CERTA GUIDELINES BE FOLLOWED WHEN TORCHING METHODS ARE EMPLOYED. THIS INCLUDES PERFORMING A FIRE WATCH FOLLOWING ANY TORCH APPLICATIONS. ALWAYS HAVE APPROVED FIRE-EXTINGUISHING EQUIPMENT NEARBY.

N.T.S

